

Note:- All combustible materials are to be removed from the vicinity of the joint to ensure that there will be no fire risk due to site welding

### Upstand Details to suit Monodraught 230 Sunpipe on Pitched Metal Roof Application

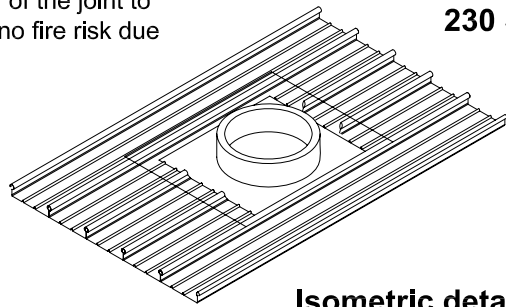

Isometric detail of roofing sheet

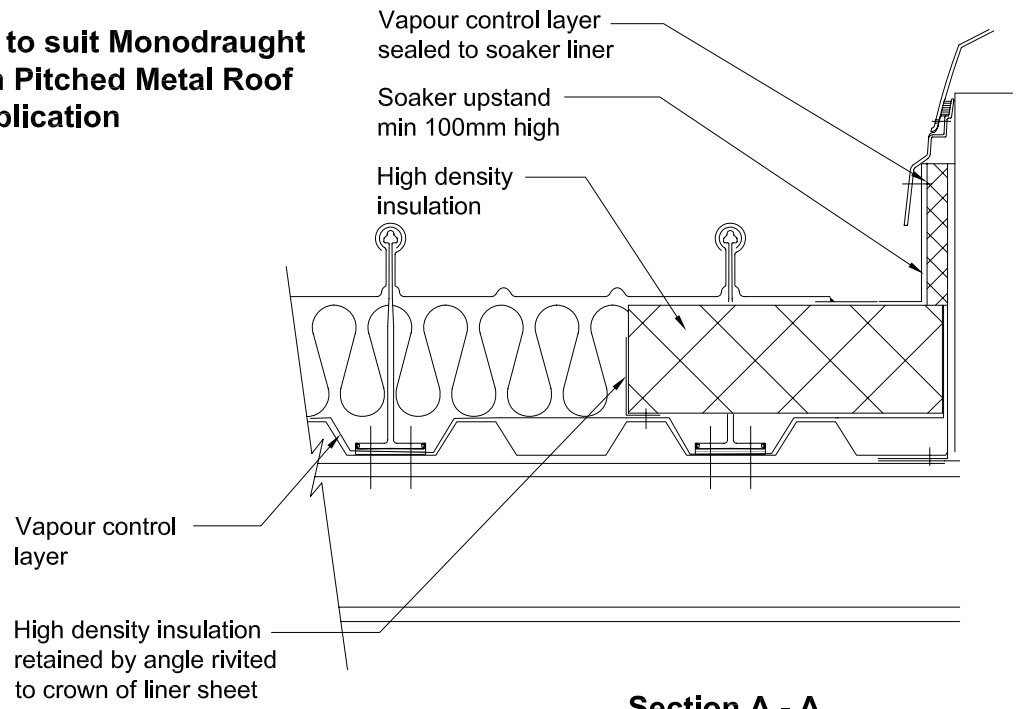
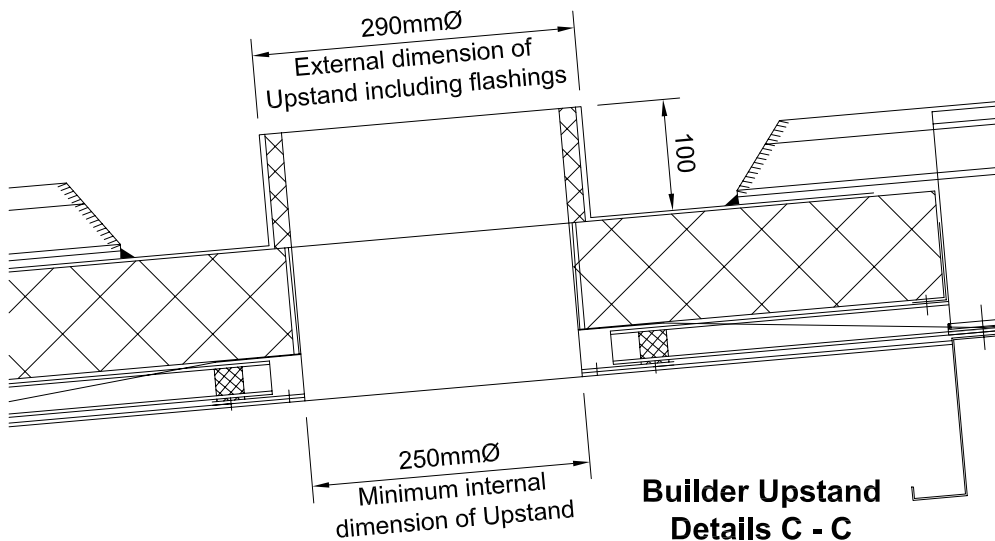
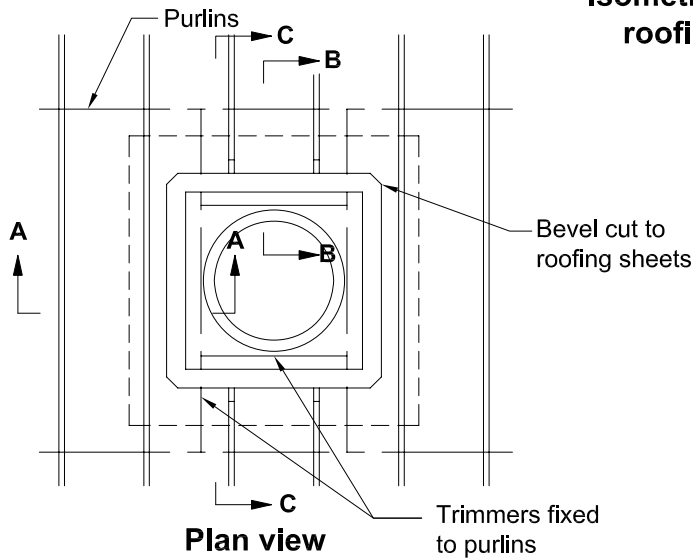

Section A - A

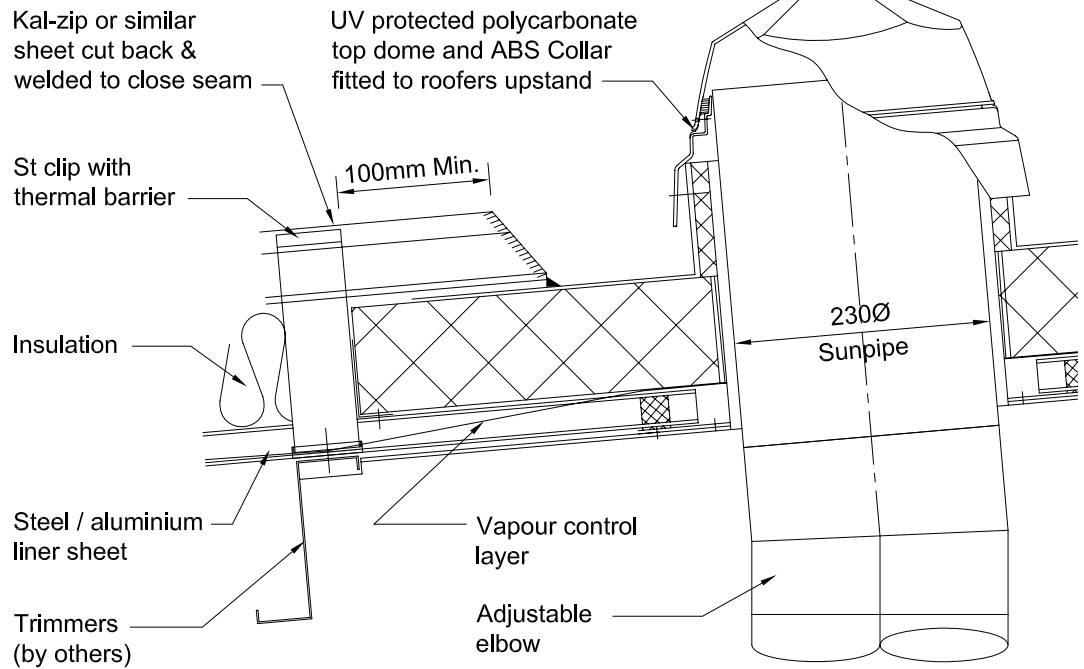

Section B - B

Monodraught