

Note:- All combustible materials are to be removed from the vicinity of the joint to ensure that there will be no fire risk due to site welding

Uprand Details to suit Monodraught 530 Sunpipe on Pitched Metal Roof Application

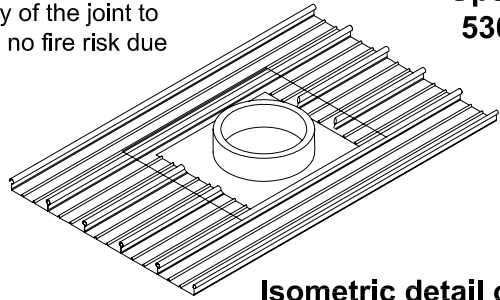

Isometric detail of roofing sheet

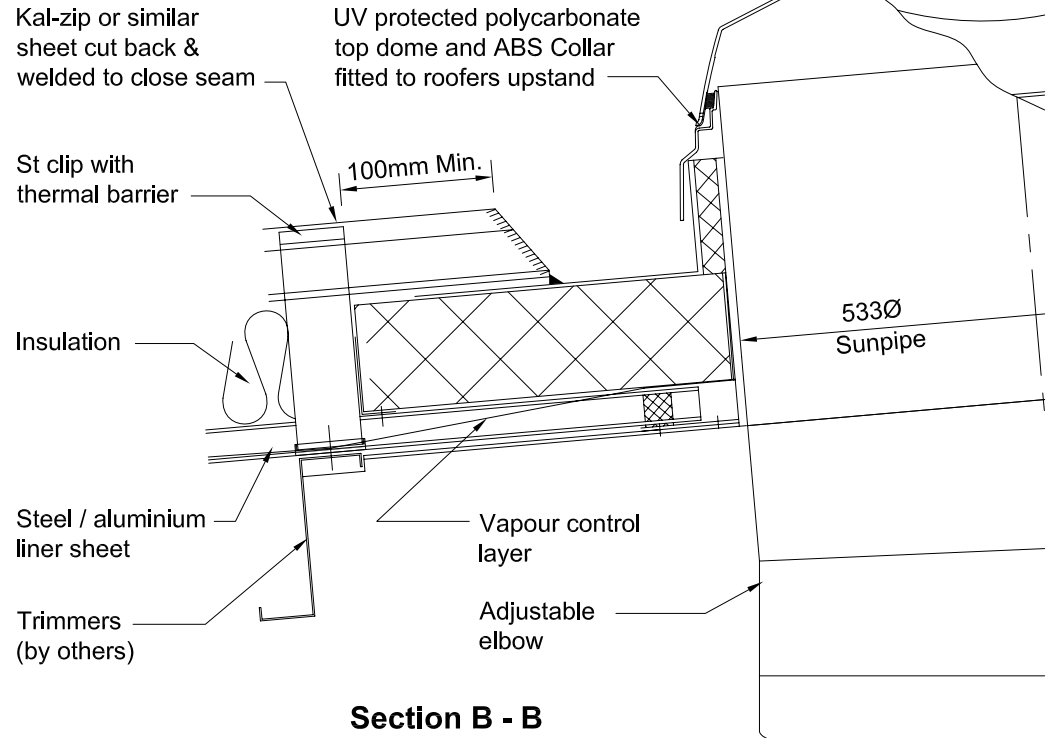
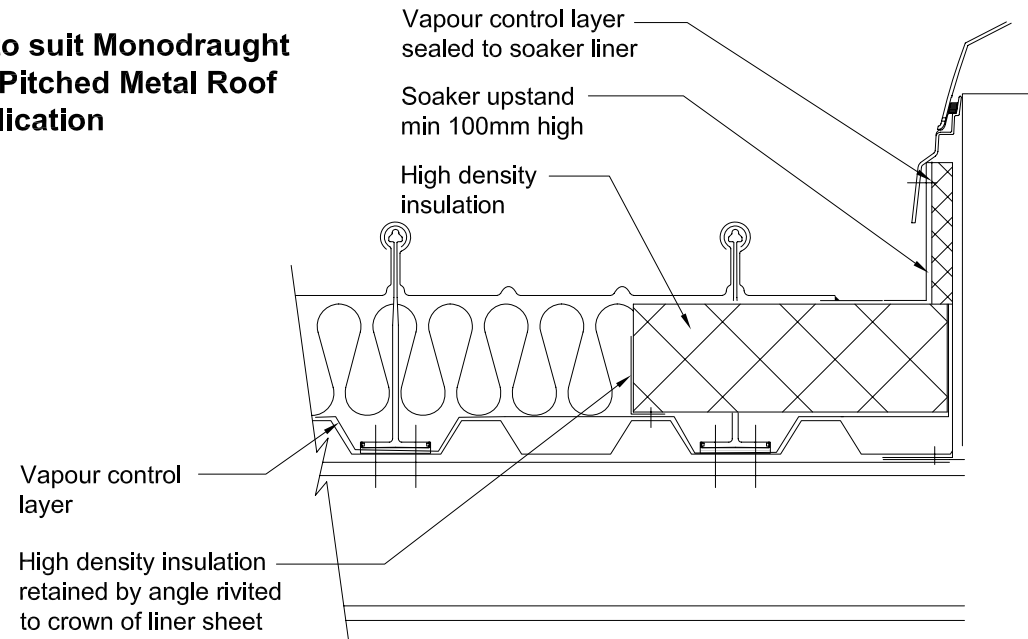
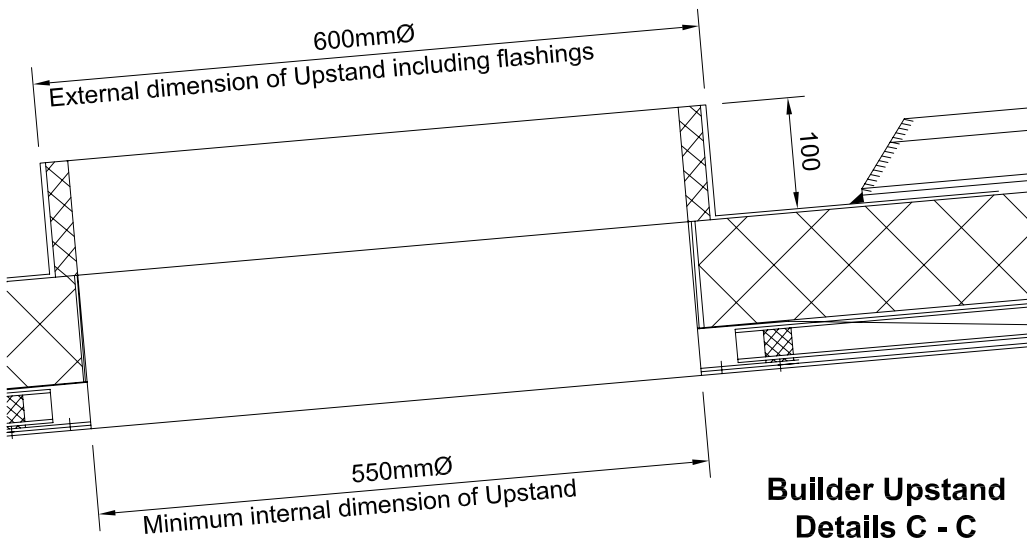
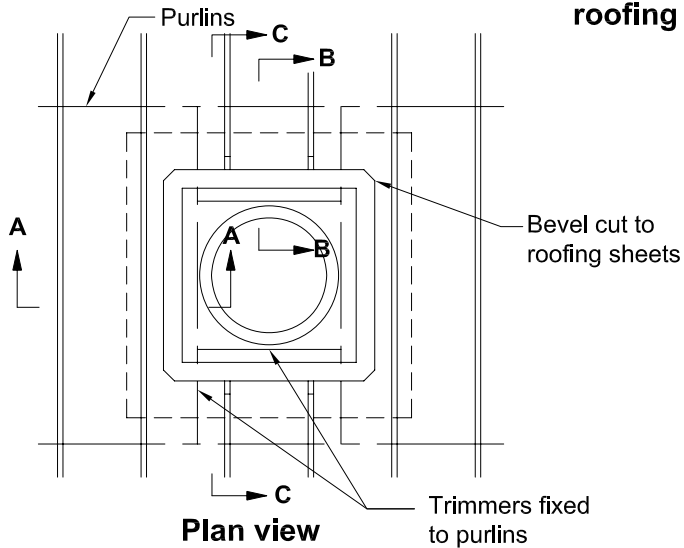

Monodraught